

Alvaline

For m

Viabizzuno

progettiamo la luce

**istruzioni di montaggio
installing instructions
Gebrauchsanweisung
instructions de montage
instrucciones de montaje**

rosone cilindrico esterno

- IT AVVERTENZE:** All'atto dell'installazione, ed ogni volta che si interviene sulla lampada, assicurarsi che sia stata tolta la tensione di alimentazione. Le operazioni di installazione e collegamento alla rete elettrica devono essere effettuate esclusivamente da personale qualificato.
- GB WARNING:** When installing fixture and during unkeep take care that the mains voltage is switched off. The operations of installation and connection to power mains should be done by skilled personnel only.
- DE HINWEISE:** Während der Installation und bei allen nachfolgenden Arbeiten auf der Lampe sollte sichergestellt werden, daß die Versorgungsspannung vorher abgenommen wurde. Die Arbeiten zur Installation und zum Anschluss an das Stromnetz sind von Fachpersonal durchzuführen.
- FR AVERTISSEMENTS:** Lors de l'installation et à chaque fois que l'on fait un entretien sur la lampe, s'assurer que la tension d'alimentation ait été coupée. Les opérations d'installation et de branchement au réseau électrique doivent être effectuées par un personnel qualifié.
- ES ADVERTENCIA:** Durante la instalación, y cada ve que se interviene sobre la lámpara, asegurarse que la alimentación haya sido desconectada. Las operaciones de instalación y conexión a la red eléctrica tienen que ser efectuadas exclusivamente por personal cualificado.

- IT ATTENZIONE:**
La sicurezza dell'apparecchio è garantita solo rispettando queste istruzioni sia in fase di installazione che di impiego.
- GB WARNING:**
Fitting safety is only guaranteed if the following instructions are strictly observed both during installation and use.
- DE ACHTUNG:**
Für die Sicherheit des Geräts kann nur dann die Garantie übernommen werden, wenn die in den vorliegenden Anweisungen enthaltenen Hinweise sowohl bei der Installation als auch beim Betrieb beachtet werden.
- FR ATTENTION:**
La sécurité de l'appareil n'est assurée que lorsque les consignes portées sont respectées, tant lors de l'installation que durant l'utilisation de l'appareil.
- ES ATENCIÓN:**
La seguridad del aparato está garantizada sólo si se respetan estas instrucciones durante la fase de instalación y de empleo.

- IT** garanzia
- GB** warranty
- DE** garantie
- FR** garantie
- ES** garantía

- IT** La presente garanzia è valida 24 mesi se timbrata e datata dal rivenditore autorizzato Viabizzuno. Il periodo di garanzia è di 2 anni a partire dalla data della timbratura e decade in caso di uso improprio, manomissione o cancellatura della data, perdita o illeggibilità del presente libretto di istruzioni.
- GB** The warranty covers 24 months if stamped and dated by the authorised Viabizzuno dealer. The 24 months warranty shall no apply in case of wrong use, altered or deleted date, or if this instructions booklet gets lost or becomes unreadable.
- DE** Die Garantie gilt 24 Monate nur, wenn sie von dem zugelassenen Verkäufer Viabizzuno gestempelt wird. Die Garantie gilt 2 Jahr seit dem Stempeldatum und verfällt bei unberechtigten Gebrauch, Manipulation des Datums, Verlust oder Unlesbarkeit von den Gebrauchsanweisungen.
- FR** La durée de la garantie est de 24 mois si elle est marquée par le distributeur autorisé Viabizzuno. La garantie est valable 2 ans depuis le jour où elle a été marquée et échoit en cas d'usage impropre, alteration ou effacement de la date, e si le carnet d'instructions est perdu ou est indéchiffrable.
- ES** Esta garantía es válida por 24 meses sólo si está datada y sellada por el revendedor autorizado Viabizzuno. El período de garantía es de 2 años a partir de la fecha del sello, y decae en caso de empleo impropio, alteración o borrado de la fecha, pérdida o ilegibilidad del presente manual de instrucciones

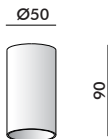

rosone esterno

F9.001.92 rosone esterno alluminio satinato argento opaco
external rose in matt silver satin finish aluminium
Äußere Abdekhülse Aluminium matt silber satiniert
rosace externe aluminium satiné argent opaque
roseton externo de aluminio satinado plateado opaco

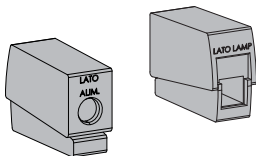
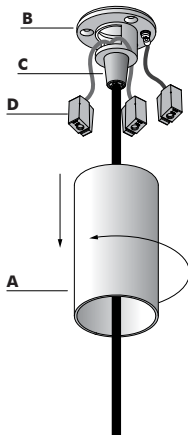

- 1. IT** rimuovere il rosone (A) svitandolo dal fondello (B). far passare il cavo elettrico della lampada attraverso il pressacavo (C), quindi eseguire il collegamento elettrico ai morsetti (D). Collegare il cavo giallo/verde di terra al morsetto contrassegnato dal simbolo ⊕
- GB** unscrew the rose (A) from the backplate (B), thread the lamp's supply cable through the cable gland (C), then connect it to the terminals (D). Connect the yellow/green earth lead to the screw marked with the symbol ⊕
- DE** Die Abdeckhülse (A) nach Abschrauben vom Hülsenboden (B) abnehmen. Das Elektrokabel der Lampe durch die Zugentlastung (C) führen, dann den Elektroanschluss an die Klemmen (D) herstellen. Das gelb/grüne Erdungskabel an die mit dem Zeichen ⊕gekennzeichnete Schraube anschließen.
- FR** retirer le cylindre (A) en le dévissant de la base (B). faire passer le câble électrique de la lampe à travers le serre-câble (C) puis réaliser le branchement électrique sur les bornes (D). Brancher le câble jaune/vert de terre à la vis portant le symbole ⊕
- ES** destornillar el rosetón (A) de la placa (B) y quitarlo. hacer pasar el cable eléctrico de la lámpara por el prensacables (C); hecho esto, efectuar la conexión eléctrica a los bornas (D). Conectar el cable amarillo/verde de tierra por debajo del tornillo marcado con el símbolo ⊕

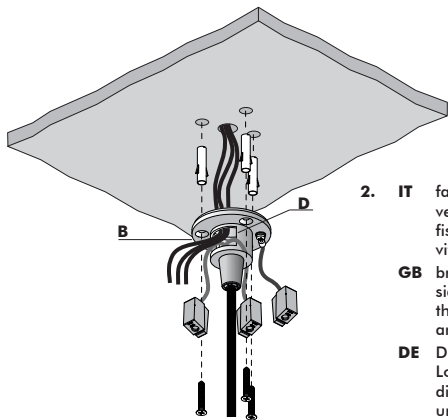

- 2. IT** far uscire cavo di alimentazione attraverso il foro laterale (E) del fondello (B) e fissare quest'ultimo a soffitto utilizzando viti e tasselli adeguati.
- GB** bring the supply cable out through the side hole (E) of the base plate (B) and fix the plate to the soffit using suitable plugs and screws.
- DE** Das Versorgungskabel durch das seitliche Loch (E) der Bodenplatte (B) führen und die Letztere mit passenden Schrauben und Dübeln an der Decke befestigen.
- FR** faire sortir le câble d'alimentation du trou latéral (E) présent sur le culot (B) puis fixer ce dernier au plafond à l'aide de vis et de chevilles appropriées.
- ES** hacer salir el cable de alimentación por el orificio lateral (E) de la placa (B) y fijar este último en el techo utilizando los tornillos y los tacos más adecuados.

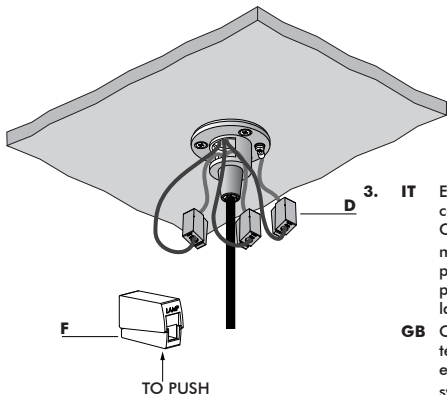

- 3. IT** Eseguire il collegamento elettrico dei cavi di alimentazione alla morsetti (D). Collegare il cavo giallo/verde di terra al morsetto contrassegnato dal simbolo ⊕ per collegare il cavo occorre premere il pulsante (F) del morsetto, inserire il cavo e lasciare il pulsante.
- GB** Connect the power supply cables to the terminals (D). Connect the yellow/green earth lead to the screw marked with the symbol ⊕. to make the connection, push in the button (F) on the terminal, insert the cable, then let the button out.
- DE** Den Elektroanschluss der Versorgungskabel an die Klemmen (D) herstellen. Das gelb/grüne Erdungskabel an die mit dem Zeichen ⊕gekennzeichnete Schraube anschließen. Zum Anschließen des Kabels den Knopf (F) der Klemme drücken, das Kabel einsetzen und den Knopf loslassen.
- FR** procéder au branchement électrique des câbles d'alimentation sur les bornes (D). Brancher le câble jaune/vert de terre à la vis portant le symbole ⊕. pour brancher le câble, il est nécessaire d'appuyer sur le bouton (F) de la borne, d'introduire le câble et de relâcher le bouton
- ES** Efectuar la conexión eléctrica de los cables de alimentación a las bornas (D). Conectar el cable amarillo/verde de tierra por debajo del tornillo marcado con el símbolo ⊕. para conectar el cable, hay que pulsar el botón (F) de la borna, introducir el cable y soltar el botón.

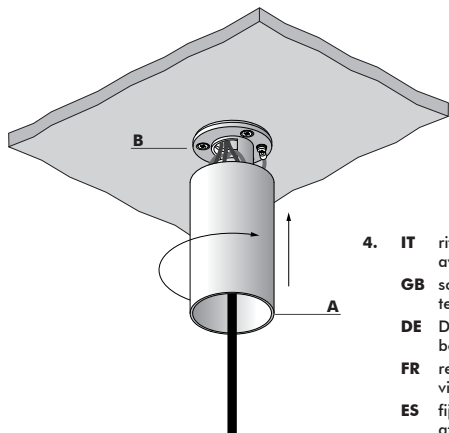

4. **IT** rifissare il rosone (A) al fondello (B) avvitandolo.
- GB** screw the rose (A) back onto the backplate (B).
- DE** Die Abdeckhülse (A) wieder am Hülsenboden (B) anbringen und festschrauben.
- FR** remettre en place le cylindre (A) en le vissant à la base (B).
- ES** fijar de nuevo el rosetón (A) a la placa (B) atornillándolo.

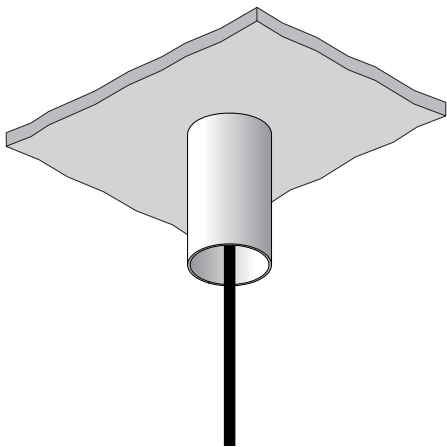



IT smaltimento dell'apparecchio

GB equipment disposal

DE entsorgung des geräts

FR élimination de l'appareil

ES eliminación del aparato

IT A fine vita l'apparecchio di illuminazione un rifiuto che rientra nella categoria Raee (Rifiuto di Apparecchiatura Elettrica ed Elettronica), pertanto non deve essere smaltito come un rifiuto municipale misto ma deve essere smaltito correttamente per evitare danni all'ambiente, alle persone e agli animali, ed evitare lo spreco di materiali riciclabili. E' possibile consegnare il vecchio apparecchio al venditore nel momento in cui si acquista un nuovo apparecchio di illuminazione, oppure portare l'apparecchio nelle aree pubbliche di raccolta predisposte dalle amministrazioni comunali, o depositarlo negli appositi contenitori.

GB At the end of the its life cycle, the light fixture should be considered as a Weee (Waste of electrical and electronic equipment) category waste, therefore it should be disposed of not as generic municipal waste, but properly in order to avoid damages to the environment, people and animals, and to avoid any waste of recyclable materials. When ordering a new light fixture, the customer may give back his/her old one to the seller, or bring it to the public collection sites arranged by the municipal authorities, or simply put it in special collection containers.

DE Am Ende der Lebensdauer ist das Gerät als Elektro- und Elektronik-Altgerät (ElektroG) zu behandeln und darf daher nicht zum Restmüll gegeben, sondern muss korrekt entsorgt werden, um die Schädigung von Umwelt, Personen und Tieren sowie die Verschwendung recycelbarer Materialien zu vermeiden. Das ausgediente Gerät kann beim Kauf eines neuen Gerätes beim Händler abgegeben oder zu einer öffentlichen Sammelstelle gebracht bzw. in den dafür vorgesehenen Behältern deponiert werden.

FR A la fin de sa durée de vie, l'appareil d'éclairage est un déchet qui entre dans la catégorie DEEE (Déchets des Equipements Electriques et Electroniques) ; il ne doit donc pas être éliminé comme un déchet municipal mixte mais correctement pour éviter tout dommage à l'environnement, aux personnes et aux animaux, et éviter le gaspillage de matériaux recyclables. Il est possible de remettre le vieil appareil au vendeur lorsque l'on achète un nouvel appareil d'éclairage, ou de porter l'appareil dans les aires publiques de collecte prévues par les administrations communales, ou de le déposer dans les contenants prévus à cet effet.

ES Al final de su vida, el aparato de iluminación es un residuo que está incluido en la categoría Raee (Residuo de aparatos eléctricos y electrónicos), por lo tanto no tiene que eliminarse como un residuo urbano mixto, sino que tiene que eliminarse de forma correcta para evitar daños al medio ambiente, a las personas y los animales, y para evitar el derroche de materiales reciclables. Es posible entregare el aparato antiguo al vendedor en el momento en qué se compre un aparato de iluminación nuevo, o bien llevar el aparato a la zona públicas de recogida preparadas por las administraciones municipales, o depositarlo en los contenedores al efecto.

Viabizzuno strada principale della frazione Bizzuno in provincia di Ravenna dove tra la casa del popolo e la parrocchia, al n°17, sono nato il ventuno luglio millenovecentocinquantacinque.

mn

Viabizzuno raccoglie attorno a sé esperienza, conoscenza e ricerca per poter meglio esprimere il proprio 'modo di fare luce'. il pensiero progettuale di Viabizzuno si identifica in una pagina bianca. due linee di prodotti complementari occupano questo spazio esplorandolo, dilatandolo: si incrociano forti della propria identità, due anime rappresentate dalle collezioni For m e Alvaline. inoltre sviluppa e realizza apparecchi di illuminazione speciali e su misura. è fondamentale che il progetto sia stimolante e che l' interlocutore sia preparato a una progettazione complessa, che richiede tempo e impegno. progettiamo la luce a 360°.

Viabizzuno is the name of the main road in the small village of Bizzuno in the province of Ravenna, where I was born on the 21st of July 1955 at No.17, between the "casa del popolo" (house of the people) and the local parish church.

mn

Viabizzuno musters experience, knowledge and research to express its "way of making light" in the best way possible. Viabizzuno's design philosophy corresponds to a blank page and two complementary product lines fill the space, exploring and expanding it; like kindred spirits, the For m and Alvaline collections interlock, confident in their own identity. Viabizzuno also designs and produces special and custom-made lighting equipment. it is essential that the project should be stimulating and that the other party is prepared for a complex design process, requiring time and commitment. we design light at 360°.



energia pulita
clean energy



For m divide lo spazio verticalmente:
equilibrata, razionale, rigorosa.

il corpo illuminante evolve nella sua
funzione di fare luce:

il suo uso é sempre più flessibile e la sua
capacità di fondersi con l'architettura
ne fa un vero materiale da costruzione,
attraverso un design non invasivo,
non mimetico, non sfacciatamente
decorativo.

i corpi illuminanti si ritraggono nelle
pareti, a filo intonaco, a scomparsa,
nascosti alla vista lasciando piena
soggettività alla luce. il grigio dei
materiali come cemento, alluminio,
acciaio é il colore della collezione For m.

For m divides space vertically; it is
balanced, rational and rigorous.

the light fitting is evolving in the way it
produces light:

it is increasingly flexible and its ability to
blend in with the architecture makes it a
genuine building material, due to its non
intrusive, non imitative design, which is
not ostentatiously ornamental.

the light fittings recede into the walls,
flush with the plaster, concealed, hidden
from view and leaving the whole scene
to the light. the colour of the For m
collection is grey, like the materials of
cement, aluminium and steel.

manuale For m 2007
manual For m 2007



italiano
cod.19091-...



english
français
русский язык
cod.19092-...



english
español
deutsch
cod.19093-...

cartella colori e finiture
folder sample finishes
and colours



cod. 19941-...

libro For m
book For m

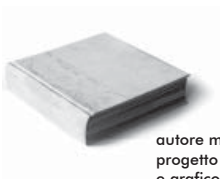

autore mario nanni
progetto editoriale
e grafico Viabizzuno
edito da Viabizzunoeditore
seconda edizione
author mario nanni
Viabizzuno publishing
and graphics project edited
by Viabizzunoeditore
second edition
cod. 15248

Alvaline attraversa lo spazio diagonalmente: dinamica, irriverente, ironica, giocosa. inizia il gesto, dove si muovono gli sguardi, dove la materia si fonde mescolandosi alla luce, si originano così colore e forma, che vivono per se stesse e per l'emozione che li circonda. il blu della notte é il suo colore.

Alvaline cuts through space diagonally; it is dynamic, irreverent, witty and playful. it makes the first move, marked by shifting glances and matter blending with the light, so colour and form are created, living a life of their own and of the emotion that surrounds them. its colour is midnight blue.



italiano
cod.16162-...



english
français
русский язык
cod.16164-...



english
español
deutsch
cod.16166-...

cartella colori e finiture
folder sample finishes
and colours



cod. 19941-...



vol.1 **E27**
cod.00285



vol.2 **h2o**
cod.00283



vol.3 **bamboo**
cod.00289



vol.4 **alva1**
cod.00291



vol.5 **clv1**
cod.00286



vol.6 **biblio**
cod.00288



vol.7 **mon amour**
cod.00282



vol.8 **emma**
cod.00287



vol.9 **clv2**
cod.00284



vol.10 **tulp**
cod.00290



vol.11 **fileau**
cod.14564



vol.13 **UpOGalleggio**
cod.15215



vol.14 **steelon**
cod.17904



vol.18 **toccamì**
cod.17777



vol.19 **la DOdò**
cod.17779



vol.20 **plag in**
cod.17778

Viabizzunoreport: strumento per incuriosirsi, conoscere ed esplorare progetti, eventi e personaggi di luce. per poter lavorare assieme é fondamentale che il lavoro da sviluppare sia un progetto stimolante e che il nostro interlocutore sia preparato ad una progettazione comunque complessa e elaborata che richiede tempo ed energia.

Viabizzunoreport: a means of gaining inspiration, getting to know and exploring projects, events and personalities in the world of light. working together requires that the project planned should be stimulating and that our partner is ready to take part in a complex and elaborate process that demands time and effort.

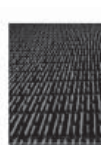

Viabizzuno srl

10 via romagnoli
40010 bentivoglio
bologna italia

t+39 0518908011

f+390518908089

www.viabizzuno.com

viabizzuno@viabizzuno.com