

Viabizzuno progettiamo la luce

**istruzioni di montaggio
installing instructions
Gebrauchsanweisung
instructions de montage
instrucciones de montaje**

n55[®]
**cassaforma laterizio scomparsa totale
brick housing total recessed**

- IT** *Viabizzuno* si riserva il diritto di apportare ai propri modelli, senza nessun preavviso, qualsiasi modifica ritenga opportuna. le nostre idee e i nostri apparecchi sono depositati e coperti da brevetti internazionali. uomo avvisato, mezzo salvato.
- EN** *Viabizzuno* reserves the right to introduce any changes to its own models, without prior notice. our ideas and our lighting fittings are registered and covered by international patents. forewarned is forearmed.
- DE** *Viabizzuno* behält sich das Recht vor jederzeit und ohne Ankündigung die technischen Daten der im Katalog abgebildeten Produkte zu ändern. unsere Ideen und unsere Beleuchtungskörper sind eingetragen und international patentiert. wer gewarnt ist, ist halb gerettet.
- FR** *Viabizzuno* se réserve le droit d'apporter une quelconque modification aux produits sans préavis. nos idées et nos corps d'illumination sont déposés et couverts de brevets internationaux. un homme averti en vaut deux.
- ES** *Viabizzuno* se reserva el derecho de aportar a sus modelos, sin ningún preaviso, cualquier modificación que considere oportuna. nuestros diseños y nuestros aparatos están todos provistos y cubiertos por patentes internacionales. el que avisa no es traidor.

- IT** garanzia
EN warranty
DE garantie
FR garantie
ES garantía

- IT** la presente garanzia è valida 24 mesi se timbrata e datata dal rivenditore autorizzato **Viabizzuno**. il periodo di garanzia è di 2 anni a partire dalla data della timbratura e decade in caso di uso improprio, manomissione o cancellatura della data, perdita o illeggibilità del presente libretto di istruzioni.
- EN** the warranty covers 24 months if stamped and dated by the authorised **Viabizzuno** dealer.
the 24 months warranty shall no apply in case of wrong use, altered or deleted date, or if this instructions booklet gets lost or becomes unreadable.
- DE** Die Garantie gilt 24 Monate nur, wenn sie von dem zugelassenen Verkäufer **Viabizzuno** gestempelt wird. Die Garantie gilt 2 Jahr seit dem Stempeldatum und verfällt bei unberechtigten Gebrauch, Manipulation des Datums, Verlust oder Unlesbarkeit von den Gebrauchsanweisungen.
- FR** la durée de la garantie est de 24 mois si elle estmarquée par le distributeur autorisé **Viabizzuno**. la garantie est valable 2 ans depuis le jour où elle a été marquée et échoit en cas d'usage impropre, alteration ou effacement de la date, e si le carnet d'instructions est perdu ou est indéchiffrable.
- ES** esta garantía es valida por 24 meses sólo si está datada y sellada por el revendedor autorizado **Viabizzuno**. el período de garantía es de 2 años a partir de la fecha del sello, y decae en caso de empleo impropio, alteración o borrado de la fecha, pérdida o ilegibilidad del presente manual de instrucciones.

- IT AVVERTENZE:** all'atto dell'installazione, ed ogni volta che si interviene sulla lampada, assicurarsi che sia stata tolta la tensione di alimentazione. le operazioni di installazione e collegamento alla rete elettrica devono essere effettuate esclusivamente da personale qualificato.
- EN WARNING:** when installing fixture and during upkeeping make sure that the mains voltage is off. the installation and connection operations to power mains should be done by skilled personnel only.
- DE HINWEISE:** Während der Installation und bei allen nachfolgenden Arbeiten auf der Lampe sollte sichergestellt werden, daß die Versorgungsspannung vorher abgenommen wurde. Die Arbeiten zur Installation und zum Anschluss an das Stromnetz sind von Fachpersonal durchzuführen.
- FR AVERTISSEMENTS:** lors de l'installation et à chaque fois que l'on fait un entretien sur la lampe, s'assurer que la tension d'alimentation ait été coupée. les opérations d'installation et de branchement au réseau électrique doivent être effectuées par un personnel qualifié.
- ES ADVERTENCIA:** durante la instalación, y cada ve que se interviene sobre la lámpara, asegurarse que la alimentación haya sido desconectada. las operaciones de instalación y conexión a la red eléctrica tienen que ser efectuadas exclusivamente por personal cualificado.
-
- IT ATTENZIONE:** la sicurezza dell'apparecchio è garantita solo rispettando queste istruzioni sia in fase di installazione che di impiego.
- EN WARNING:** fitting safety is only guaranteed if the following instructions are strictly observed both during installation and use.
- DE ACHTUNG:** Für die Sicherheit des Geräts kann nur dann die Garantie übernommen werden, wenn die in den vorliegenden Anweisungen enthaltenen Hinweise sowohl bei der Installation als auch beim Betrieb beachtet werden.
- FR ATTENTION:** la sécurité de l'appareil n'est assurée que lorsque les consignes portées sont respectées, tant lors de l'installation que durant l'utilisation de l'appareil.
- ES ATENCIÓN:** la seguridad del aparato está garantizada sólo si se respetan estas instrucciones durante la fase de instalación y de empleo.

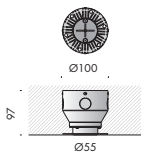

accessori. accessories.

CE

Vb9.580.74 cassaforma laterizio scomparsa totale
brick housing total recessed
Backstein- Unterputzkasten
coffrage pour brique à encastrement total
arqueta completamente al ras en ladrillo

1.

esempi di installazione installation example

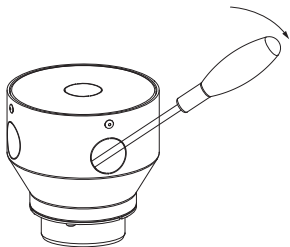
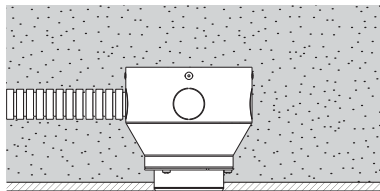

finitura superficiale
surface finish
Oberflächenfinish
finition de surface
acabado de la superficie

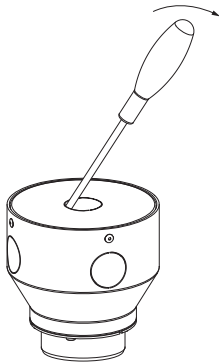
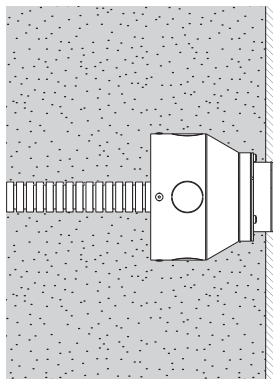

finitura superficiale
surface finish
Oberflächenfinish
finition de surface
acabado de la superficie

min. 120

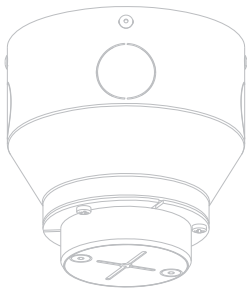
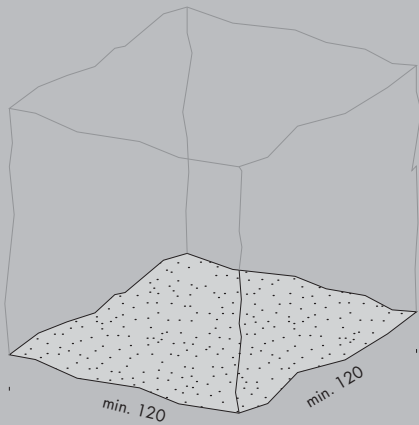

3.

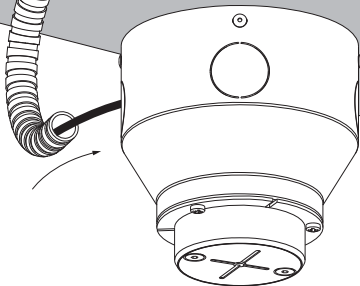
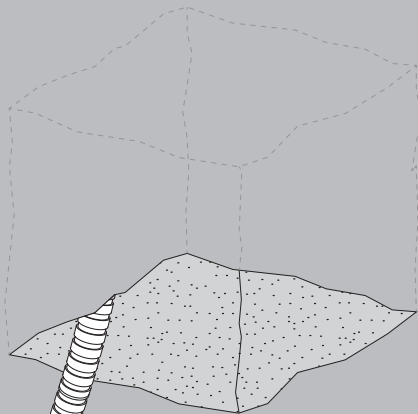

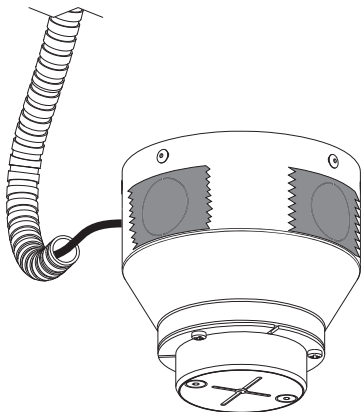

IT si raccomanda di proteggere la i fori non utilizzati della cassaforma con del nastro adesivo al fine di evitare l'ingresso di liquidi e polvere nella stessa.

EN it is recommended to protect the unused holes of the formwork with adhesive tape in order to prevent the entrance of liquids and dust into itself.

5.

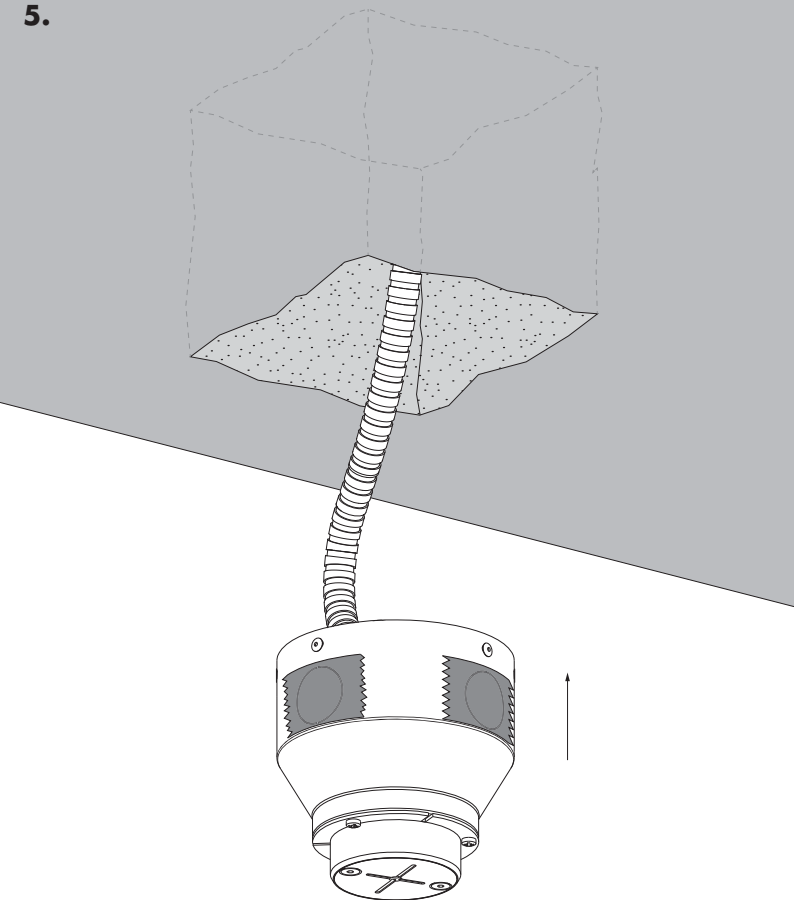

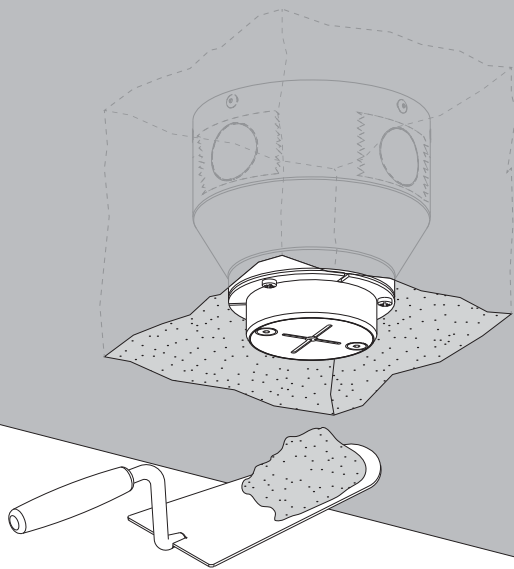

7.

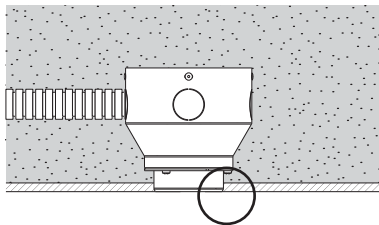

OK

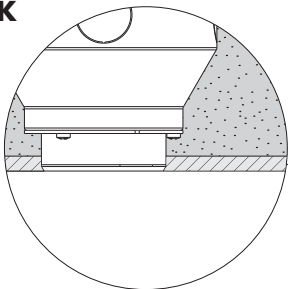

finitura superficiale
surface finish
Oberflächenfinish
 finition de surface
acabado de la superficie

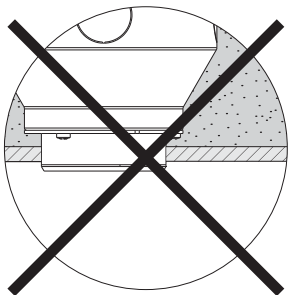

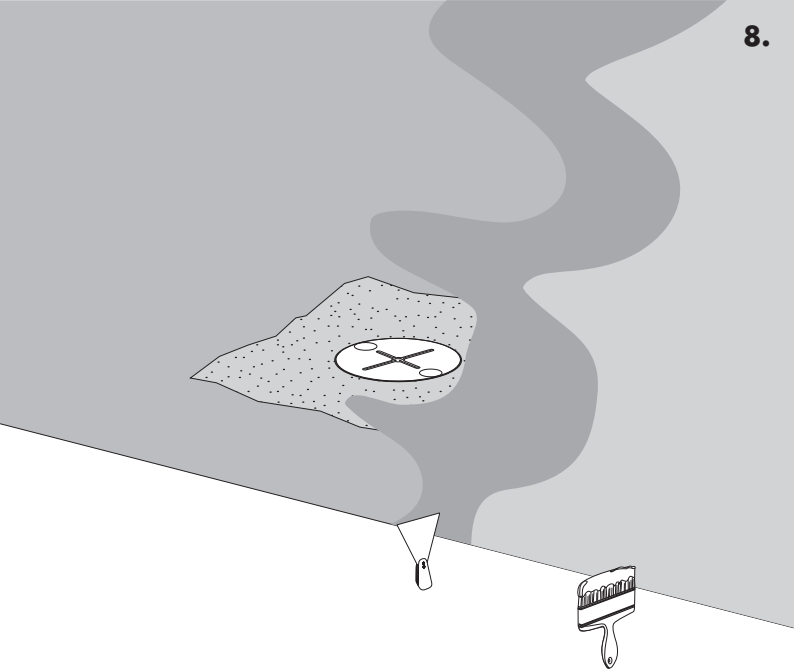

- IT** stuccare, rasare e verniciare.
EN fill, skim and decorate.
DE verspachteln, abschaben und streichen.
FR stuquer, raser et peindre.
ES enmasillar, pulir y pintar.

9.

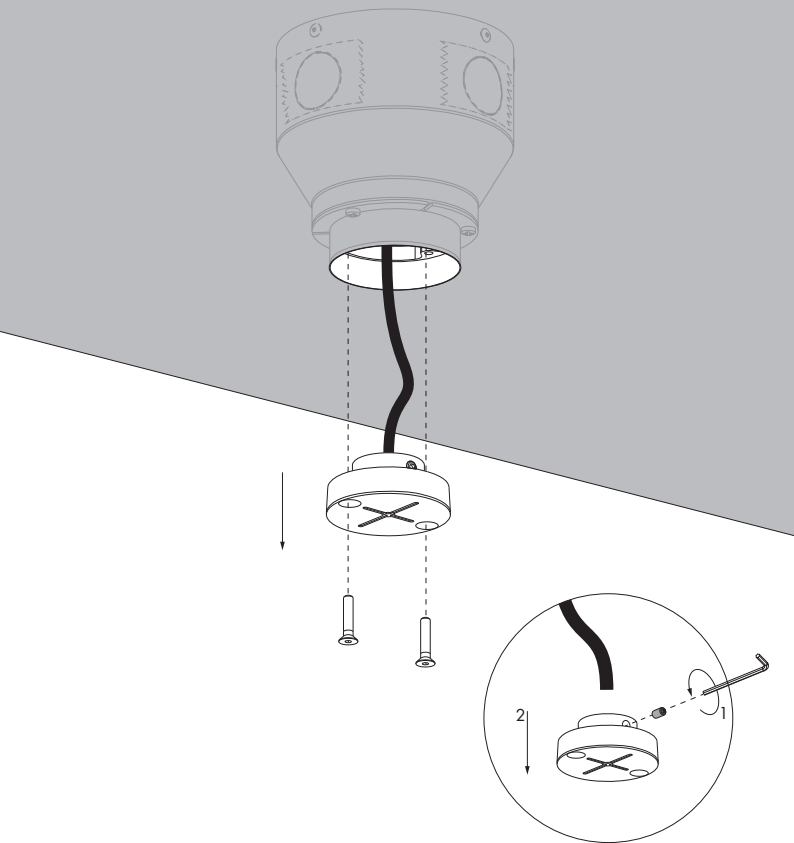

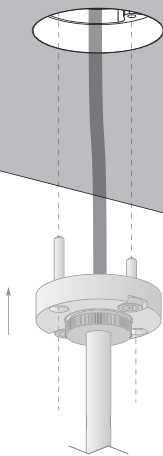



Viabizzuno strada principale della frazione di bizzuno in provincia di ravenna dove tra la casa del popolo e la parrocchia, al n°17, sono nato il ventuno luglio millenovecentocinquantaquattro. da qui nasce il nome dell'azienda fondata nel millenovecentonovantaquattro rappresentata da uno spazio bianco attraversato da due linee, una verticale, rigorosa, pulita, equilibrata, ed una inclinata, irriverente nello spazio, ironica, fuori dagli schemi. distinte ma complementari proprio come le due anime rappresentate dalle due collezioni Viabizzuno. e nel punto in cui si intersecano le due linee, l'UpO, Ufficio progettazione Ombre.

Viabizzuno is the name of the main road of the small village bizzuno located in the province of ravenna, where I was born on the 21 07 1955 at n°17, between the 'casa del popolo' and the local parish church. from here the name of the company founded in nineteen ninety-four represented by a white space intersected by two lines one vertical, well balanced, logical, clean, the other dynamic, irreverent, ironic, separate and yet complementary, just like the two different philosophies behind Viabizzuno two collections. in the intersection between the two lines, UpO, Ufficio progettazione Ombre.



superficie complessiva/total area 19.070 m²
volume complessivo/total volume 108.000 m³



il libro For m: riflessione, studio, sperimentazione e progettazione attorno alla luce, ma soprattutto strumento a disposizione di chi voglia individuare un proprio percorso di luce attraverso la nostra raccolta di 30 anni di lavoro, documentata da 569 immagini. un libro dedicato alla luce, in cui la si possa conoscere, capire e, perché no, anche toccare in 3 pagine termosensibili.

the book For m: reflection, study, experimentation and design based on lighting, but most of all, the tool that is available to anyone who wants to identify these methods using our collection of thirty years of work, all documented with 569 images. this book is dedicated to light, where one can learn, understand and why not, even touch 3 thermo-sensitive pages.



libro For m finitura cemento bianco
prima edizione, 2005, esaurito
book For m cement finishing
first edition, 2005, out of stock



libro For m finitura gomma
seconda edizione, 2007, esaurito
book For m rubber finishing
second edition, 2007, out of stock



libro For m
terza edizione, 2011, esaurito
book For m
third edition, 2011, out of stock

Viabizzuno srl

10 via romagnoli

40010 bentivoglio

bologna italia

t+39 05 18908011

f+390518908089

www.viabizzuno.com

viabizzuno@viabizzuno.com