

**Alvaline**

**For m**

**Viabizzuno**

**progettiamo la luce**

**istruzioni di montaggio  
installing instructions  
Gebrauchsanweisung  
instructions de montage  
instrucciones de montaje**

**vase-big feet-m3** kit halopar





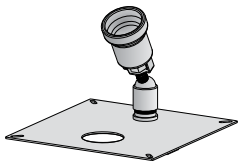

- IT AVVERTENZE:** All'atto dell'installazione, ed ogni volta che si interviene sulla lampada, assicurarsi che sia stata tolta la tensione di alimentazione. Le operazioni di installazione e collegamento alla rete elettrica devono essere effettuate esclusivamente da personale qualificato.
- GB WARNING:** When installing fixture and during unkeep take care that the mains voltage is switched off. The operations of installation and connection to power mains should be done by skilled personnel only.
- DE HINWEISE:** Während der Installation und bei allen nachfolgenden Arbeiten auf der Lampe sollte sichergestellt werden, daß die Versorgungsspannung vorher abgenommen wurde. Die Arbeiten zur Installation und zum Anschluss an das Stromnetz sind von Fachpersonal durchzuführen.
- FR AVERTISSEMENTS:** Lors de l'installation et à chaque fois que l'on fait un entretien sur la lampe, s'assurer que la tension d'alimentation ait été coupée. Les opérations d'installation et de branchement au réseau électrique doivent être effectuées par un personnel qualifié.
- ES ADVERTENCIA:** Durante la instalación, y cada ve que se interviene sobre la lámpara, asegurarse que la alimentación haya sido desconectada. Las operaciones de instalación y conexión a la red eléctrica tienen que ser efectuadas exclusivamente por personal cualificado.

- IT ATTENZIONE:**  
La sicurezza dell'apparecchio è garantita solo rispettando queste istruzioni sia in fase di installazione che di impiego.
- GB WARNING:**  
Fitting safety is only guaranteed if the following instructions are strictly observed both during installation and use.
- DE ACHTUNG:**  
Für die Sicherheit des Geräts kann nur dann die Garantie übernommen werden, wenn die in den vorliegenden Anweisungen enthaltenen Hinweise sowohl bei der Installation als auch beim Betrieb beachtet werden.
- FR ATTENTION:**  
La sécurité de l'appareil n'est assurée que lorsque les consignes portées sont respectées, tant lors de l'installation que durant l'utilisation de l'appareil.
- ES ATENCIÓN:**  
La seguridad del aparato está garantizada sólo si se respetan estas instrucciones durante la fase de instalación y de empleo.

- IT** garanzia  
**GB** warranty  
**DE** garantie  
**FR** garantie  
**ES** garantía

- IT** La presente garanzia è valida 24 mesi se timbrata e datata dal rivenditore autorizzato Viabizzuno. Il periodo di garanzia è di 2 anni a partire dalla data della timbratura e decade in caso di uso improprio, manomissione o cancellatura della data, perdita o illeggibilità del presente libretto di istruzioni.
- GB** The warranty covers 24 months if stamped and dated by the authorised Viabizzuno dealer. The 24 months warranty shall no apply in case of wrong use, altered or deleted date, or if this instructions booklet gets lost or becomes unreadable.
- DE** Die Garantie gilt 24 Monate nur, wenn sie von dem zugelassenen Verkäufer Viabizzuno gestempelt wird. Die Garantie gilt 2 Jahr seit dem Stempeldatum und verfällt bei unberechtigten Gebrauch, Manipulation des Datums, Verlust oder Unlesbarkeit von den Gebrauchsanweisungen.
- FR** La durée de la garantie est de 24 mois si elle est marquée par le distributeur autorisé Viabizzuno. La garantie est valable 2 ans depuis le jour où elle a été marquée et échoit en cas d'usage impropre, alteration ou effacement de la date, e si le carnet d'instructions est perdu ou est indéchiffrable.
- ES** Esta garantía es válida por 24 meses sólo si está datada y sellada por el revendedor autorizado Viabizzuno. El período de garantía es de 2 años a partir de la fecha del sello, y decae en caso de empleo impropio, alteración o borrado de la fecha, pérdida o ilegibilidad del presente manual de instrucciones



**kit di cablaggio**    **250V-50/60Hz**        
**F9.002.01**    kit halopar 30    HRGI    E27    75W

- IT** ATTENZIONE: l'apparecchio non va montato in giornate particolarmente umide o di pioggia.
- GB** ATTENTION: the lighting fixture should not be fitted in particularly humid or rainy days.
- DE** ACHTUNG: Das Gerät darf nicht an Tagen mit feuchter Witterung oder Regenwetter montiert werden.
- FR** ATTENTION: l'appareil ne doit pas être monté lorsqu'il fait particulièrement humide ou lorsqu'il pleut.
- ES** ATENCIÓN : el aparato no tiene que montarse durante días especialmente húmedos o de lluvia

1.

- IT** ATTENZIONE:  
utilizzare cavo del tipo H07RN-F
- GB** ATTENTION: use cable type H07RN-F.
- DE** ACHTUNG:  
Kabel vom Typ H07RN-F verwenden.
- FR** ATTENTION:  
utiliser un câble de type H07RN-F
- ES** ATENCIÓN: Utilizar cable de tipo H07RN-F.

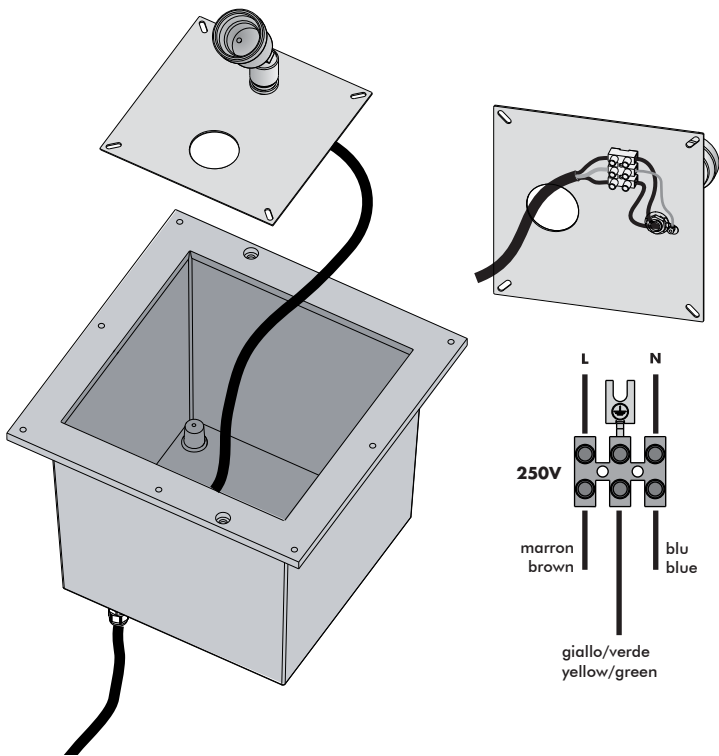

2.

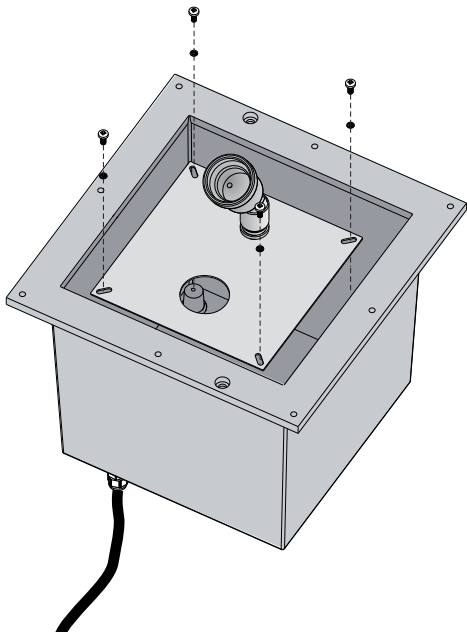

**3.**

- IT** Inserire la lampadina [di caratteristiche adeguate, vedi marcatura sull'apparecchio] sul portalampada.
- GB** Fit a lamp [of suitable specification see the labelling on the fitting] to the lampholder.
- DE** Eine passende Glühbirne (siehe Angaben auf der Leuchte) in die Fassung einsetzen
- FR** Monter l'ampoule [de caractéristiques appropriées, voir indications sur l'appareil] sur la douille.
- ES** Poner la bombilla [de características adecuadas, véase marca en el aparato] en el portalámparas.

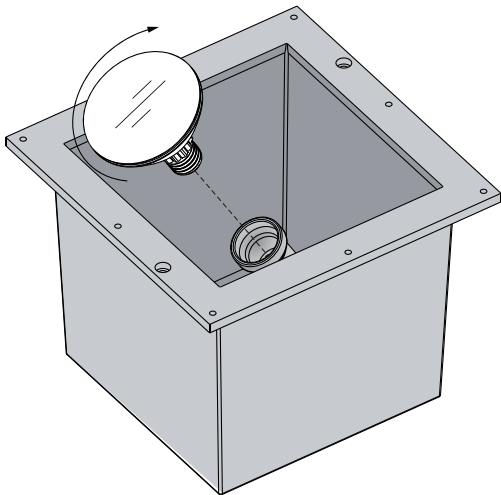

4.

- IT** Accendere l'apparecchio lasciando la lampadina accesa per almeno 15 minuti prima di chiudere il corpo, in modo da eliminare l'umidità interna.
- GB** Turn the fixture on, thus leaving the bulb on for at least 15 minutes before closing the body, in such a way to eliminate moisture inside.
- DE** Das Gerät einschalten und die Lampe mindestens 15 brennen lassen, bevor der Beleuchtungskörper geschlossen wird, um die Feuchtigkeit entweichen zu lassen.
- FR** Allumer l'appareil en laissant l'ampoule allumée pendant au moins 15 minutes avant de fermer le corps, de manière à éliminer l'humidité interne.
- ES** Encender el aparato dejando la bombilla encendida durante al menos 15 minutos antes de cerrar el cuerpo, de modo de eliminar la humedad interior.

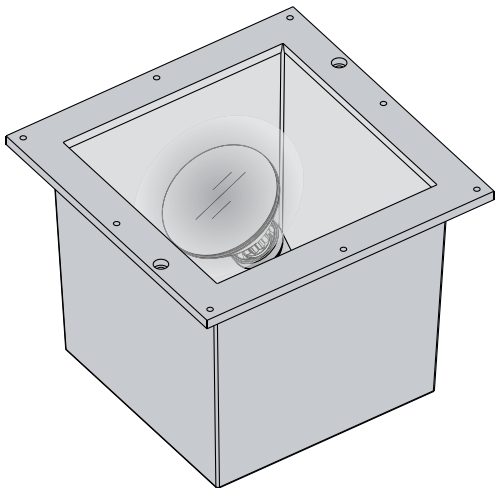





**IT smaltimento dell'apparecchio**

**GB equipment disposal**

**DE entsorgung des geräts**

**FR elimination de l'appareil**

**ES eliminación del aparato**

**IT** A fine vita l'apparecchio di illuminazione un rifiuto che rientra nella categoria Raee (Rifiuto di Apparecchiatura Elettrica ed Elettronica), pertanto non deve essere smaltito come un rifiuto municipale misto ma deve essere smaltito correttamente per evitare danni all'ambiente, alle persone e agli animali, ed evitare lo spreco di materiali riciclabili. E' possibile consegnare il vecchio apparecchio al venditore nel momento in cui si acquista un nuovo apparecchio di illuminazione, oppure portare l'apparecchio nelle aree pubbliche di raccolta predisposte dalle amministrazioni comunali, o depositarlo negli appositi contenitori.

**GB** At the end of the its life cycle, the light fixture should be considered as a Weee (Waste of electrical and electronic equipment) category waste, therefore it should be disposed of not as generic municipal waste, but properly in order to avoid damages to the environment, people and animals, and to avoid any waste of recyclable materials. When ordering a new light fixture, the customer may give back his/her old one to the seller, or bring it to the public collection sites arranged by the municipal authorities, or simply put it in special collection containers.

**DE** Am Ende der Lebensdauer ist das Gerät als Elektro- und Elektronik-Altergerät (ElektroG) zu behandeln und darf daher nicht zum Restmüll gegeben, sondern muss korrekt entsorgt werden, um die Schädigung von Umwelt, Personen und Tieren sowie die Verschwendung recycelbarer Materialien zu vermeiden. Das ausgediente Gerät kann beim Kauf eines neuen Gerätes beim Händler abgegeben oder zu einer öffentlichen Sammelstelle gebracht bzw. in den dafür vorgesehenen Behältern deponiert werden.

**FR** A la fin de sa durée de vie, l'appareil d'éclairage est un déchet qui entre dans la catégorie DEEE (Déchets des Equipements Electriques et Electroniques) ; il ne doit donc pas être éliminé comme un déchet municipal mixte mais correctement pour éviter tout dommage à l'environnement, aux personnes et aux animaux, et éviter le gaspillage de matériaux recyclables. Il est possible de remettre le vieil appareil au vendeur lorsque l'on achète un nouvel appareil d'éclairage, ou de porter l'appareil dans les aires publiques de collecte prévues par les administrations communales, ou de le déposer dans les contenants prévus à cet effet.

**ES** Al final de su vida, el aparato de iluminación es un residuo que está incluido en la categoría Raee (Residuo de aparatos eléctricos y electrónicos), por lo tanto no tiene que eliminarse como un residuo urbano mixto, sino que tiene que eliminarse de forma correcta para evitar daños al medio ambiente, a las personas y los animales, y para evitar el derroche de materiales reciclables. Es posible entregare el aparato antiguo al vendedor en el momento en qué se compre un aparato de iluminación nuevo, o bien llevar el aparato a la zona públicas de recogida preparadas por las administraciones municipales, o depositarlo en los contenedores al efecto.

- IT** indice marcature  
**GB** marking index  
**DE** Kennzeichenverzeichnis  
**FR** index de marquage  
**ES** indice de marcado



- IT** classe 1 (solo isolamento fondamentale; inoltre le parti conduttrici accessibili sono collegate ad un conduttore di terra. Messa a terra tassativa).  
**GB** class1 (only basic insulation, accessible conductors are earthed. Earthing compulsory).  
**DE** Klass 1 (Grundisolation leitenden; berührbare Metallteile sind mit Schutzerdung verbunden. Schutzerdung vorgeschrieben)  
**FR** class 1 (seulement isolation de base, les parties conductrices accessibles sont reliées à un conducteur terre. Mise à la terre obligatoire).  
**ES** Clase 1 (sólo aislamiento fundamental; además, las partes conductoras accesibles están conectadas a un conductor de tierra. Puesta a tierra indispensable).



- IT** Apparecchi idonei al montaggio diretto su superfici normalmente incombustibili  
**GB** Luminaries suitable for direct mounting on flammable surfaces  
**DE** Geeignet fuer direkt Einbau auf entzuenlichen Oberflaechen  
**FR** Appareil predisposé à un montage direct sur une superficie normalment inflammable  
**ES** Aparatos adecuados para el montaje directo sobre superficies normalmente inflamables



- IT** Lampade con vetro UV-STOP  
**GB** Lamp with UV-STOP glass  
**DE** Lampe mit UV-STOP Filter  
**FR** Lampes avec verre anti-UV  
**ES** Lámparas con cristal UV-STOP.



- IT** Lampade impiegabili in apparecchi senza schermo di protezione supplementare  
**GB** Lamps to be used in fittings without additional protection glass  
**DE** Kein zusätzlich Schtzglas notwendig  
**FR** Lampes utilisables dans des appareils sans écrans de protections  
**ES** Bombillas utilizables en aparatos sin pantalla de protección suplementaria.
- CE** **IT** prodotto conforme alle direttive europee  
**GB** produced in compliance with EC directives  
**DE** Gebaut gemaeß EG-Vorschriften  
**FR** produit conforme aux Directives de la Communauté Européenne  
**ES** Producto conforme con las directivas europeas



Viabizzuno strada principale della frazione Bizzuno in provincia di ravenna dove tra la casa del popolo e la parrocchia, al n°17, sono nato il ventuno luglio millenovecentocinquantacinque.

mn

**Viabizzuno** raccoglie attorno a sé esperienza, conoscenza e ricerca per poter meglio esprimere il proprio 'modo di fare luce'. il pensiero progettuale di Viabizzuno si identifica in una pagina bianca. due linee di prodotti complementari occupano questo spazio esplorandolo, dilatandolo: si incrociano forti della propria identità, due anime rappresentate dalle collezioni For m e Alvaline. inoltre sviluppa e realizza apparecchi di illuminazione speciali e su misura. è fondamentale che il progetto sia stimolante e che l' interlocutore sia preparato a una progettazione complessa, che richiede tempo e impegno.

progettiamo la luce a 360°.

Viabizzuno is the name of the main road of the small village Bizzuno, located in the province of ravenna, where I was born on the 21st of july 1955 at n°17, between the "casa del popolo" and the local parish church.

mn

**Viabizzuno** channels together experience, knowledge and research to express its "way of making light" as best as possible. Viabizzuno planning concepts are exalted when posed before a blank page; two complementary product lines occupy the space by exploring it and expanding it. they entwine together without vanishing thanks to their clear-cut identity. distinct yet complementary just like the two souls represented by the two Viabizzuno collections For m and Alvaline. it designs and produces special and custom-made lighting equipment too. it is essential that the project is stimulating and that the other party is prepared for a complex design process, requiring time and commitment.

we design ligh at 360°.



***energia pulita***  
***clean energy***



**For m** divide lo spazio verticalmente: equilibrata, razionale, rigorosa. il corpo illuminante evolve nella sua funzione di fare luce:

il suo uso é sempre più flessibile e la sua capacità di fondersi con l'architettura ne fa un vero materiale da costruzione, attraverso un design non invasivo, non mimetico, non sfacciatamente decorativo.

i corpi illuminanti si ritraggono nelle pareti, a filo intonaco, a scomparsa, nascosti alla vista lasciando piena soggettività alla luce. il grigio dei materiali come cemento, alluminio, acciaio é il colore della collezione For m.

**For m** divides space vertically. it is balanced, rational and rigorous. the lighting element is an evolution in the way that light is shed: its way of being used becomes evermore flexible and its capacity of blending with the surrounding architecture makes it a true building material, thanks to its non-intrusive yet non-mimetic design, which is not brazenly decorative. the recessed lighting elements retract into the wall, grazing against the plaster to hide away from sight and leave the whole scene to the light. the gray of materials like cement, aluminium, and steel is the colour of the For m collection.

manuale For m 2007  
manual For m 2007



italiano  
cod.19091-...



english  
français  
русский язык  
cod.19092-...



english  
español  
deutsch  
cod.19093-...

cartella colori e finiture  
folder sample finishes  
and colours



cod. 19941-...

libro For m  
book For m

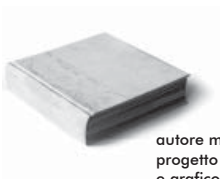

autore mario nanni  
progetto editoriale  
e grafico Viabizzuno  
edito da Viabizzunoeditore  
seconda edizione  
author mario nanni  
Viabizzuno publishing  
and graphics project edited  
by Viabizzunoeditore  
second edition  
cod. 15248

**Alvaline** attraversa lo spazio diagonalmente: dinamica, irriverente, ironica, giocosa. inizia il gesto, dove si muovono gli sguardi, dove la materia si fonde mescolandosi alla luce, si originano così colore e forma, che vivono per se stesse e per l'emozione che li circonda. il blu della notte é il suo colore.

**Alvaline** cuts through space diagonally with dynamism, irreverence, irony and playfulness. its gesture is marked by the shifting of glances, by the blending of matter with light thus giving life to colour and form which live a life of their own with the emotions surrounding them. midnight blue is its colour.





italiano  
cod.16162-...



english  
français  
русский язык  
cod.16164-...



english  
español  
deutsch  
cod.16166-...

cartella colori e finiture  
folder sample finishes  
and colours



cod. 19941



vol.1 **E27**  
cod.00285



vol.2 **h2o**  
cod.00283



vol.3 **bamboo**  
cod.00289



vol.4 **alva1**  
cod.00291



vol.5 **clv1**  
cod.00286



vol.6 **biblio**  
cod.00288



vol.7 **mon amour**  
cod.00282



vol.8 **emma**  
cod.00287



vol.9 **clv2**  
cod.00284



vol.10 **tulp**  
cod.00290



vol.11 **fileau**  
cod.14564



vol.13 **UpOGalleggio**  
cod.15215



vol.14 **steelon**  
cod.17904



vol.18 **toccamì**  
cod.17777



vol.19 **la DOdò**  
cod.17779



vol.20 **plag in**  
cod.17778

**Viabizzunoreport:** strumento per incuriosirsi, conoscere ed esplorare progetti, eventi e personaggi di luce. per poter lavorare assieme é fondamentale che il lavoro da sviluppare sia un progetto stimolante e che il nostro interlocutore sia preparato ad una progettazione comunque complessa e elaborata che richiede tempo ed energia.

**Viabizzunoreport:** an instrument to get one to be intrigued, and to come to know and explore projects, events and personalities linked to the world of light. working together requires that the project to be developed is stimulating and that our partner is ready to take part in a complex and elaborate process that demands time and energy.

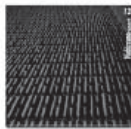

**Viabizzuno** srl

10 via romagnoli  
40010 bentivoglio  
bologna italia

t+39 0518908011

f+390518908089

[www.viabizzuno.com](http://www.viabizzuno.com)

[viabizzuno@viabizzuno.com](mailto:viabizzuno@viabizzuno.com)